

APC Laser Diode™

ADL-65075SA2

Perfect Solution For Auto Power Controlled Laser Diode

By converting the external APC circuit board into an ASIC, we package the APC circuit into a traditional TO-can together with the laser chip. From now on, single package APC function included laser diode is realized.

Powered with Arima's proprietary **APC Laser Diode™** technology, **ADL-65075SA2** is your perfect solution for the stable light power output, compact size, high brightness laser light source.

Features:

1. 3.3mm package and 650nm 7mW 70°C operation
2. Low operation current
3. Saving space and cost of laser module
4. Voltage driven LD, easy to use

Applications:

1. General purpose red laser light source
2. Laser pointer
3. Industrial laser markers / measuring instruments

6-2D-LD65-014 _Rev.01



ADL-65075SA2 Electrical-Optical Characteristics @T_c=25°C:

Item	Symbol	Min.	Typ.	Max	Unit	Condition
Wavelength	λ	645	650	660	nm	P _o =7mW
Operation current	I _{op}	-	25	35	mA	P _o =7mW
Variable resistor	VR	1	3.5	7	K Ω	V _{cc} =3V
Parallel divergence angle	$\theta_{//}$	6	9	12	Deg	P _o =7mW
Perpendicular divergence angle	θ_{\perp}	25	30	32	Deg	
Parallel FFP deviation angle	$\Delta\theta_{//}$	-3.0	0	+3.0	Deg	
Perpendicular FFP deviation angle	$\Delta\theta_{\perp}$	-3.0	0	+3.0	Deg	
Emission point accuracy	$\Delta x \Delta y \Delta z$	-80	0	+80	um	-
Power-Temp stability (25~70 °C)	ΔP_{oT}	-20	-10	0	%	Po=7mW,Vcc=3.0V
Power-V _{cc} stability (6.0~3.5V)	ΔP_{oV}	-15	-10	0	%	Po=7mW,Temp=25°C

Maximum Ratings:

Item	Symbol	Rating	Unit
Power supply voltage	V _{cc}	2.5-6.0*	V
Laser optical output power	P _o	10	mW
Operation temperature	T _{opr}	-10 ~ +70	°C
Storage temperature	T _{stg}	-40 ~ +85	°C

* Effective heat sink is recommended on 6V case due to extra heat.

Block Diagram:

1. Traditional LD needs to connect an external APC circuit board for the constant power operation. The VR (variable resistor) is used to adjust the laser output to a desired target power.
2. **ADL-65075SA2** consists an APC IC inside the **TO-3.3mm** package, and leaves the VR outside for adjusting the optical output power.
3. Oscillation Damper is recommended for stabilizing the optical output power.

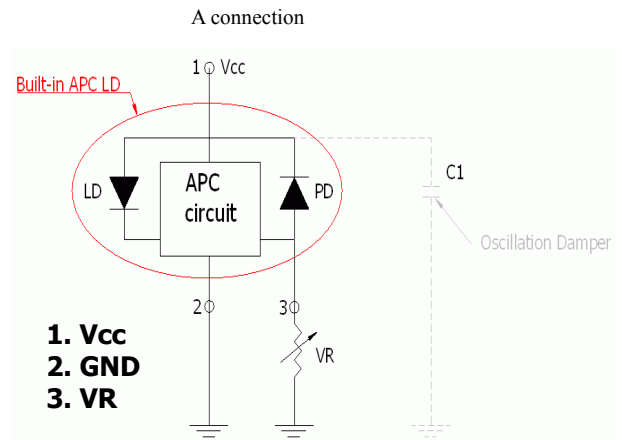

Outline Dimension & Pin Assignment:

1. V_{cc}
2. GND
3. VR

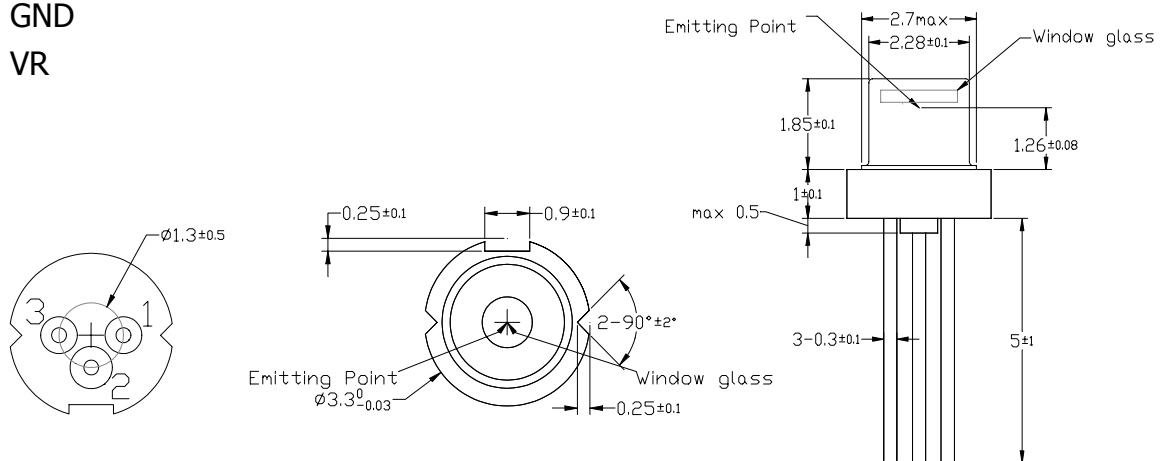

Laser Safety Precautions

1. To protect laser from overdriving condition, setting VR to maximum value before you turn on Vcc can minimized the laser output power.
2. Do not operate the device above the maximum rating condition, even momentarily. It may cause unexpected permanent damage to the device.
3. Semiconductor laser device is very sensitive to electrostatic discharge. High voltage spike current may change the characteristics of the device, or malfunction at any time during its service period. Therefore, proper measures for preventing electrostatic discharge are strongly recommended.
4. To obtain a stable characteristic and good reliability, the effective heat sink is necessary. So it is recommended that always apply proper heat sink before the device is operating.-
5. Do not look into the laser beam directly by bare eyes. The laser beam may cause severe damage to human eyes.